

KB TYPE

– Standard Type –

This type is a metric dimension series generally used in Europe.

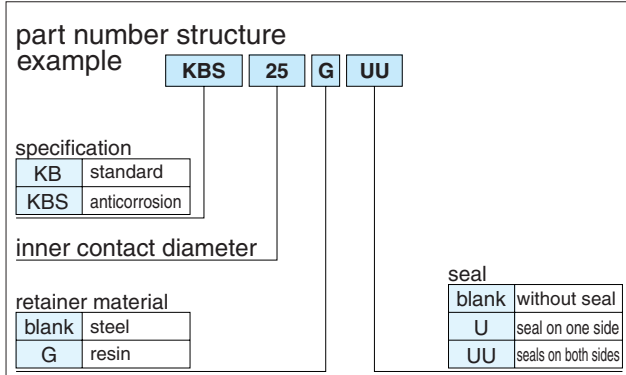

part number				number of ball circuits	dr			
standard		anticorrosion			mm	tolerance μm	D	
steel retainer	resin retainer	stainless retainer	resin retainer				mm	tolerance μm
KB 3	KB 3G	KBS 3	KBS 3G	4	3		7	
KB 4	KB 4G	KBS 4	KBS 4G	4	4		8	0
KB 5	KB 5G	KBS 5	KBS 5G	4	5	+ 8	12	- 8
KB 8	KB 8G	KBS 8	KBS 8G	4	8	0	16	
KB10	KB10G	KBS10	KBS10G	4	10		19	0
KB12	KB12G	KBS12	KBS12G	4	12		22	- 9
KB16	KB16G	KBS16	KBS16G	4	16	+ 9	26	
KB20	KB20G	KBS20	KBS20G	5	20	- 1	32	0
KB25	KB25G	KBS25	KBS25G	6	25	+11	40	-11
KB30	KB30G	KBS30	KBS30G	6	30	- 1	47	
KB40	KB40G	KBS40	KBS40G	6	40	+13	62	0
KB50	KB50G	KBS50	KBS50G	6	50	- 2	75	-13
KB60	KB60G	KBS60	KBS60G	6	60		90	0
KB80	—	—	—	6	80	+16/-4	120	-15

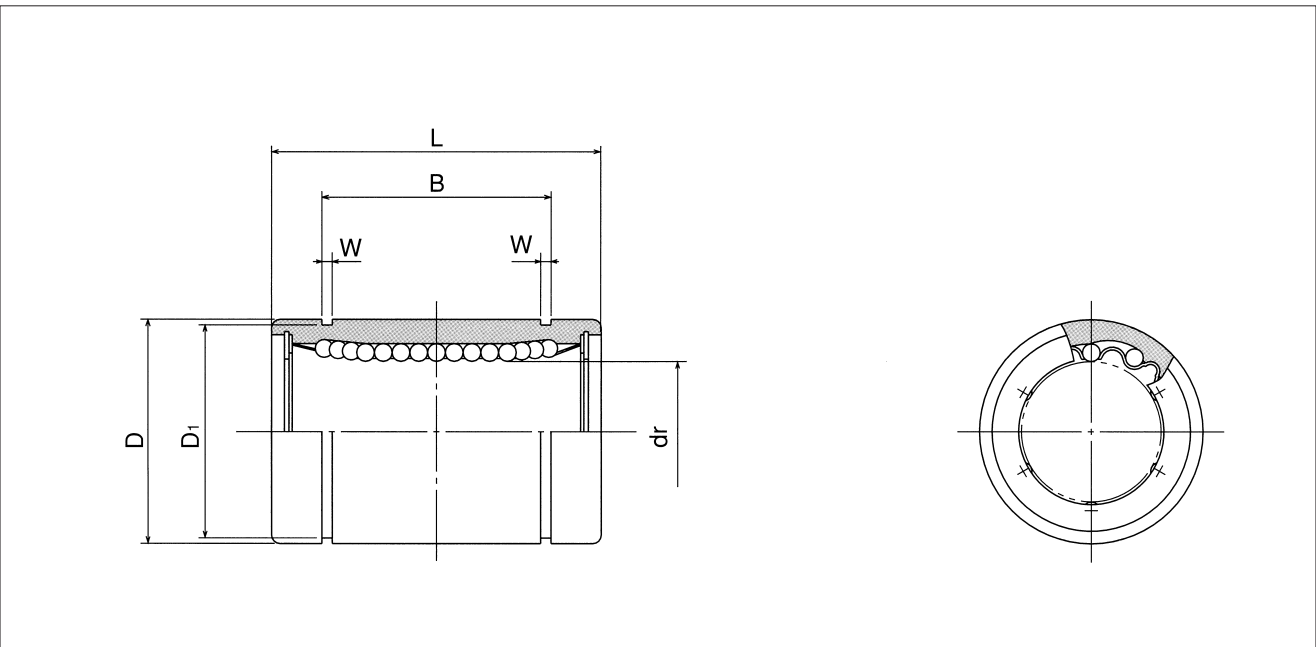

major dimensions						eccentricity μm	radial clearance (maximum) μm	basic load rating		mass g	shaft diameter mm
mm	L	B		W mm	D ₁ mm			dynamic C N	static C ₀ N		
	tolerance mm	mm	tolerance mm								
10	0	—	—	—	—	10	- 3	69	105	1.4	3
12	-0.12	—	—	—	—			88	127	2	4
22	0	14.5	0	1.1	11.5			12	- 4	206	265
25		16.5		1.1	15.2	265	402			22	8
29		22		1.3	18	372	549			36	10
32		-0.2		22.9	1.3	21	510			784	45
36	-0.2	24.9	-0.2	1.3	24.9	15	- 6	578	892	60	16
45		31.5		1.6	30.3			862	1,370	102	20
58		44.1		1.85	37.5			980	1,570	235	25
68	0	52.1	0	1.85	44.5	17	- 8	1,570	2,740	360	30
80	-0.3	60.6	-0.3	2.15	59			2,160	4,020	770	40
100	0	77.6	0	2.65	72	20	- 13	3,820	7,940	1,250	50
125		101.7		3.15	86.5			4,700	9,800	2,220	60
165		-0.4		133.7	-0.4			4.15	116	7,350	16,000

1N \approx 0.102kgf

KB-AJ TYPE

– Clearance Adjustable Type –

This type is a metric dimension series generally used in Europe.

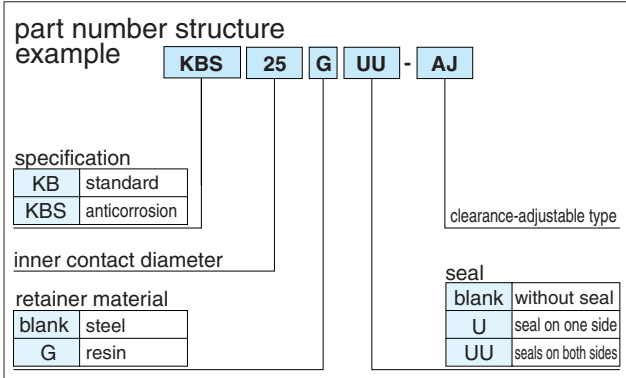

part number				number of ball circuits	D			
standard		anticorrosion			dr		D	
steel retainer	resin retainer	stainless retainer	resin retainer		mm	tolerance* μm	mm	tolerance* μm
—	KB 5G-AJ	—	KBS 5G-AJ	4	5	+ 8 0	12	0
—	KB 8G-AJ	—	KBS 8G-AJ	4	8		16	- 8
—	KB10G-AJ	—	KBS10G-AJ	4	10		19	0
KB12-AJ	KB12G-AJ	KBS12-AJ	KBS12G-AJ	4	12	+ 9 - 1	22	- 9
KB16-AJ	KB16G-AJ	KBS16-AJ	KBS16G-AJ	4	16		26	0
KB20-AJ	KB20G-AJ	KBS20-AJ	KBS20G-AJ	5	20		32	- 11
KB25-AJ	KB25G-AJ	KBS25-AJ	KBS25G-AJ	6	25	+11	40	0
KB30-AJ	KB30G-AJ	KBS30-AJ	KBS30G-AJ	6	30	- 1	47	- 11
KB40-AJ	KB40G-AJ	KBS40-AJ	KBS40G-AJ	6	40	+13 - 2	62	0
KB50-AJ	KB50G-AJ	KBS50-AJ	KBS50G-AJ	6	50		75	- 13
KB60-AJ	KB60G-AJ	KBS60-AJ	KBS60G-AJ	6	60		90	0
KB80-AJ	—	—	—	6	80	+16/-4	120	- 15

* Accuracy is measured prior to machining clearance slot.

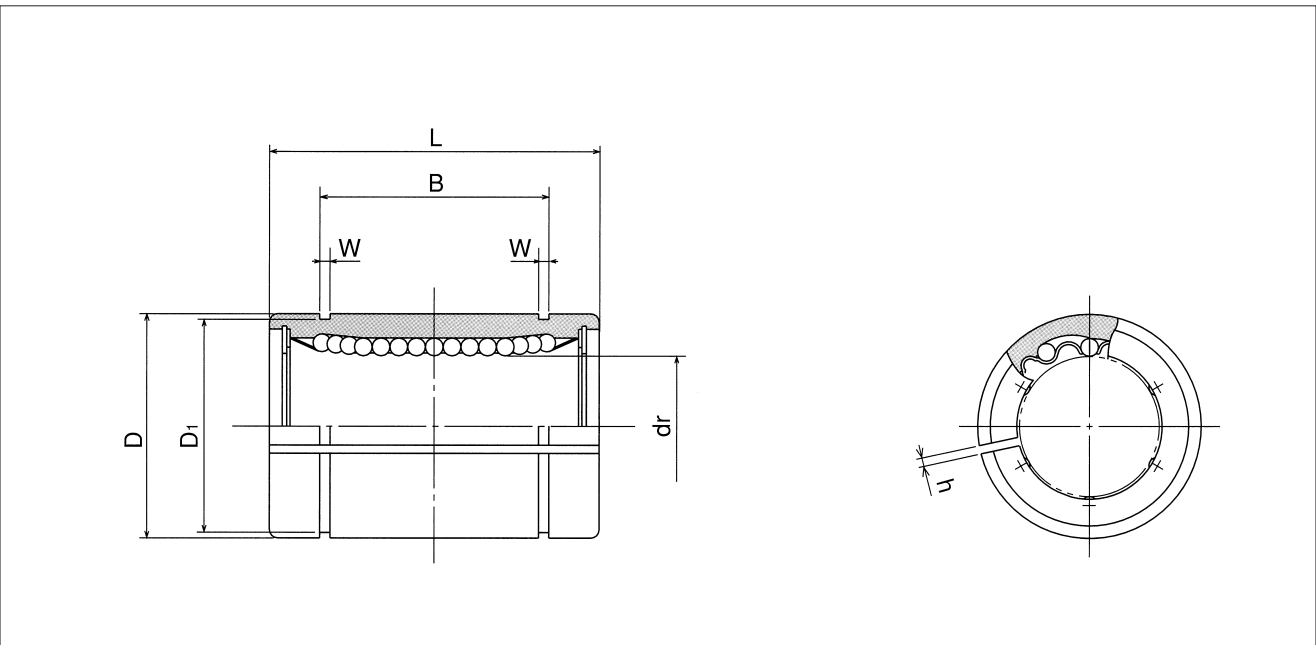

major dimensions							eccentricity* μm	basic load rating		mass g	shaft diameter mm
mm	L	mm	B	mm	D ₁	h		dynamic	static		
	tolerance mm		tolerance mm					C	C ₀		
22		14.5		1.1	11.5	1	12	206	265	10	5
25		16.5		1.1	15.2	1		265	402	19.5	8
29	0	22	0	1.3	18	1		372	549	29	10
32	-0.2	22.9	-0.2	1.3	21	1.5		510	784	44	12
36		24.9		1.3	24.9	1.5		578	892	59	16
45		31.5		1.6	30.3	2	15	862	1,370	100	20
58		44.1		1.85	37.5	2		980	1,570	230	25
68	0	52.1	0	1.85	44.5	2	17	1,570	2,740	355	30
80	-0.3	60.6	-0.3	2.15	59	3		2,160	4,020	758	40
100		77.6		2.65	72	3		3,820	7,940	1,230	50
125	0	101.7	0	3.15	86.5	3	20	4,700	9,800	2,170	60
165	-0.4	133.7	-0.4	4.15	116	3		7,350	16,000	5,000	80

1N ≙ 0.102kgf

KB-OP TYPE

— Open Type —

This type is a metric dimension series generally used in Europe.

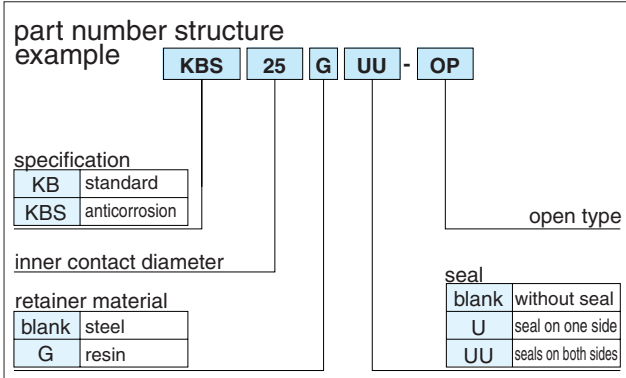
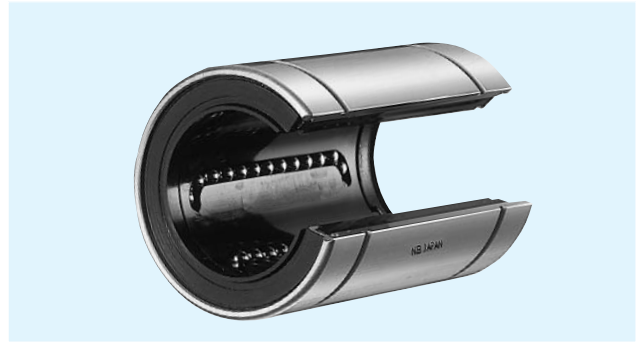

part number				number of ball circuits	D			
standard		anticorrosion			dr		D	
steel retainer	resin retainer	stainless retainer	resin retainer		mm	tolerance* μm	mm	tolerance* μm
—	KB10G-OP	—	KBS10G-OP	3	10	+ 8	19	0
KB12-OP	KB12G-OP	KBS12-OP	KBS12G-OP	3	12	0	22	- 9
KB16-OP	KB16G-OP	KBS16-OP	KBS16G-OP	3	16	+ 9	26	0
KB20-OP	KB20G-OP	KBS20-OP	KBS20G-OP	4	20	- 1	32	- 11
KB25-OP	KB25G-OP	KBS25-OP	KBS25G-OP	5	25	+11	40	0
KB30-OP	KB30G-OP	KBS30-OP	KBS30G-OP	5	30	- 1	47	- 11
KB40-OP	KB40G-OP	KBS40-OP	KBS40G-OP	5	40	+13	62	0
KB50-OP	KB50G-OP	KBS50-OP	KBS50G-OP	5	50	- 2	75	- 13
KB60-OP	KB60G-OP	KBS60-OP	KBS60G-OP	5	60		90	0
KB80-OP	—	—	—	5	80	+16/-4	120	- 15

* Accuracy is measured prior to machining open slot.

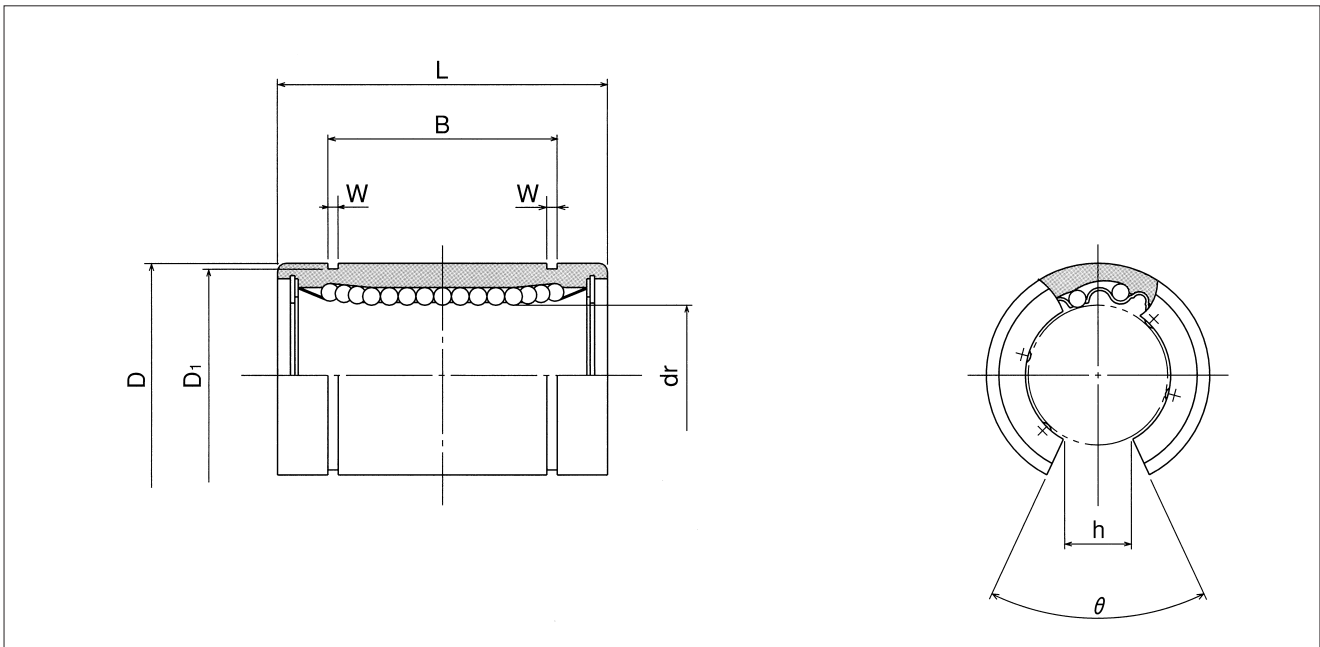

major dimensions								eccentricity μm	basic load rating		mass g	shaft diameter mm
mm	L	mm	tolerance mm	mm	mm	mm	θ		dynamic	static		
	tolerance mm								C N	Co N		
29		22		1.3	18	6.8	80°	12	372	549	23	10
32	0	22.9	0	1.3	21	7.5	78°		510	784	35	12
36	-0.2	24.9	-0.2	1.3	24.9	10	78°		578	892	48	16
45		31.5		1.6	30.3	10	60°	15	862	1,370	84	20
58		44.1		1.85	37.5	12.5	60°		980	1,570	195	25
68	0	52.1	0	1.85	44.5	12.5	50°		1,570	2,740	309	30
80	-0.3	60.6	-0.3	2.15	59	16.8	50°	17	2,160	4,020	665	40
100		77.6		2.65	72	21	50°		3,820	7,940	1,080	50
125	0	101.7	0	3.15	86.5	27.2	54°	20	4,700	9,800	1,900	60
165	-0.4	133.7	-0.4	4.15	116	36.3	54°		7,350	16,000	4,380	80

1N \approx 0.102kgf

KB-W TYPE

— Double-Wide Type —

This type is a metric dimension series generally used in Europe.

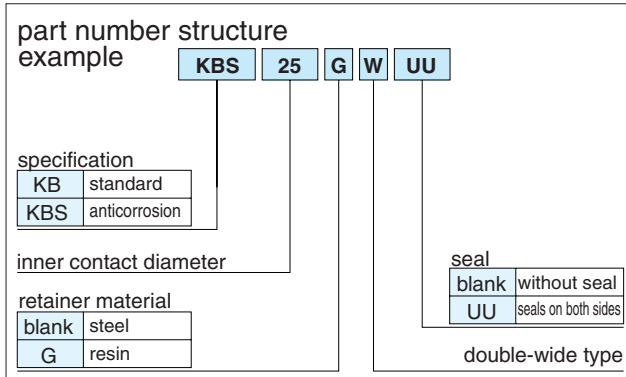

part number				number of ball circuits	dr			
standard		anticorrosion			mm	tolerance μm	D	
steel retainer	resin retainer	stainless retainer	resin retainer				mm	tolerance μm
KB 8W	KB 8GW	KBS 8W	KBS 8GW	4	8	+ 9	16	0/-9
KB12W	KB12GW	KBS12W	KBS12GW	4	12	- 1	22	0
KB16W	KB16GW	KBS16W	KBS16GW	4	16	+11	26	-11
KB20W	KB20GW	KBS20W	KBS20GW	5	20	- 1	32	0
KB25W	KB25GW	KBS25W	KBS25GW	6	25	+13	40	-13
KB30W	KB30GW	KBS30W	KBS30GW	6	30	- 2	47	0
KB40W	KB40GW	KBS40W	KBS40GW	6	40	+16	62	-15
KB50W	KB50GW	KBS50W	KBS50GW	6	50	- 4	75	0/-20
KB60W	KB60GW	KBS60W	KBS60GW	6	60		90	

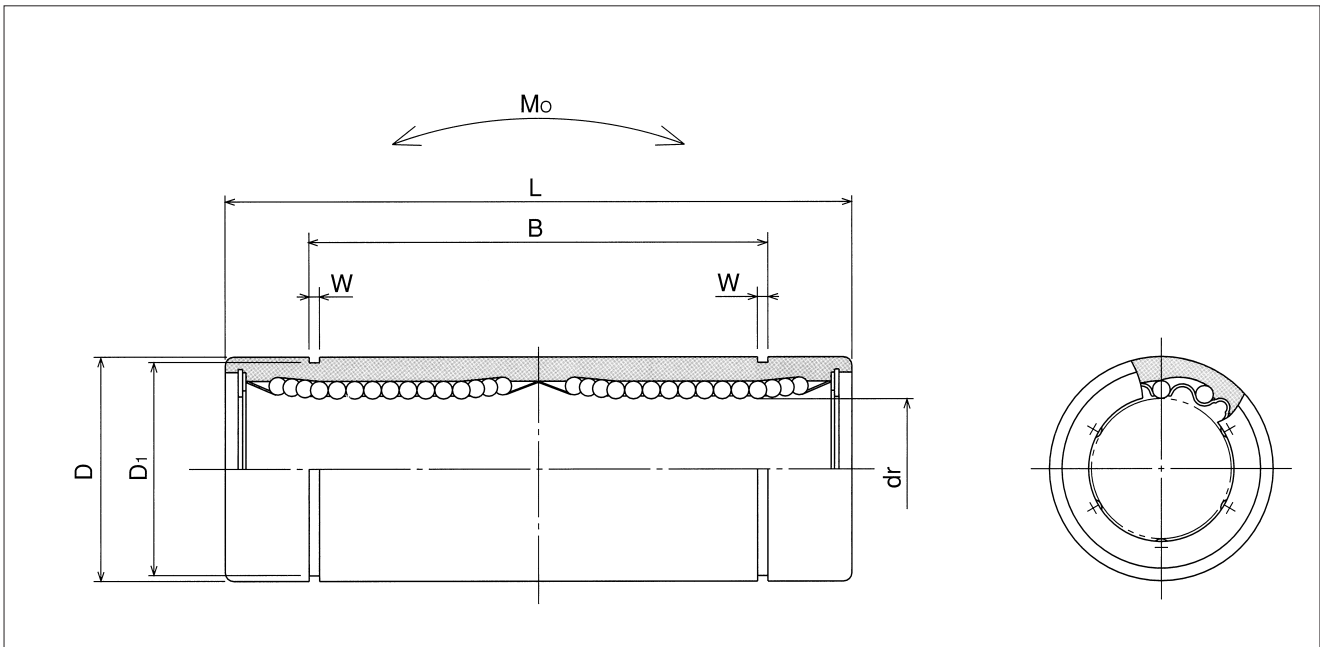

major dimensions						eccentricity	basic load rating		Allowable static moment M_o	mass	shaft diameter
L	B	W	D_1		dynamic		static				
mm	tolerance mm	mm	tolerance mm	mm	mm	μm	C	C_o	$N \cdot m$	g	mm
46		33		1.1	15.2	15	421	804	4.3	40	8
61	0	45.8	0	1.3	21		813	1,570	11.7	80	12
68	-0.3	49.8	-0.3	1.3	24.9		921	1,780	14.2	115	16
80		61		1.6	30.5	17	1,370	2,740	25.0	180	20
112		82		1.85	38		1,570	3,140	44.0	430	25
123	0	104.2	0	1.85	44.5		2,500	5,490	78.9	615	30
151	-0.4	121.2	-0.4	2.15	59	20	3,430	8,040	147	1,400	40
192		155.2		2.65	72		6,080	15,900	396	2,320	50
209		170		3.15	86.5		7,550	20,000	487	3,920	60

1N \approx 0.102kgf 1N·m \approx 0.102kgf·m